

CPAP

Model #: _____

Provider Name: _____

Serial #: _____

Phone #: _____

Date: _____

Contact Person: _____

Setting up your equipment:

For setting up your equipment, you will have:

- CPAP/BIPAP compressor
- 6 ft. of corrugated (flexible) tubing
- Patient interface; i.e. mask or nasal pillows
- Headgear
- Humidifier (optional)

(See Diagram 1)

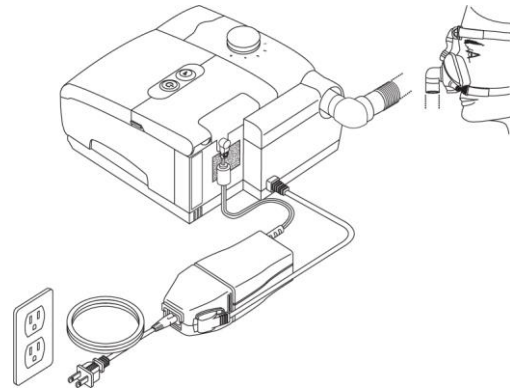

Diagram 1

(Photo image with humidifier)

The equipment provider will have preset the pressure on your machine according to your physician's orders.

Using your equipment:

- Plug unit into a grounded and working outlet
- Attach or connect flex tubing into CPAP/BIPAP unit
- Attach patient interface to opposite end of tubing
- Unhook headgear straps and thread through slots in the mask. Fasten the mask onto the headgear straps and adjust for the largest size possible. (See Diagram 2)
- Hold the mask in place over the nose, pressing gently against your face; slide headgear over your head. Adjust the straps. (See Diagram 3)
- To remove mask, unfasten the bottom straps and then slide mask up over your head.
- If your mask does not look like the one in the diagram below, ask your equipment provider for information on your specific mask.

Diagram 2

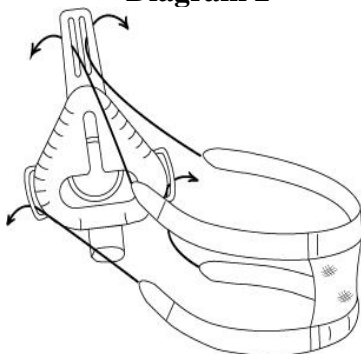
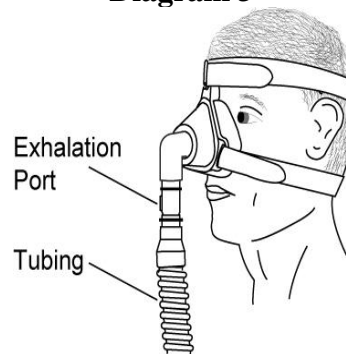

Diagram 3



Maintenance:

- If your unit is supplied with a foam filter, it must be cleaned (rinsed with water) every week.
- If your unit has a disposable filter, it should be replaced at least every month.
- Masks should be cleaned with mild soap and water every day.
- Tubing should be cleaned with mild soap and water every week and allowed to air dry.
- Unit should be wiped down with damp cloth as needed.
- Headgear should be hand or machine washed periodically.
- The humidifier, if present, should be cleaned with mild soap and water weekly.

Special Procedures:

- If nasal drying occurs, the use of a humidifier may be recommended. The humidifier runs between the CPAP/BIPAP compressor and the flexible tubing. Fill the humidifier with distilled water. Refer to specific operators manual for cleaning instructions.
- Hints for mask comfort:
 - Wash face thoroughly before each use to remove excess oils.
 - Do not over-tighten the head strap. Over-tightening can irritate your face and cause damage to the mask.
- If any of the following occur, contact your physician.
 - Runny nose
 - Nasal, sinus or ear pain
 - Obstructive sleep apnea symptoms recur or persist
 - Light-headedness or dizziness

Frequent replacement items:

- Filters
- Masks/nasal pillow system or headgear
- Tubing
- Pillows/cushions

Safety Issues:

The following conditions may contraindicate the use of CPAP/BIPAP:

- Bullous Lung Disease
- Pneumothorax
- Pneumocephalus
- Low Blood Pressure

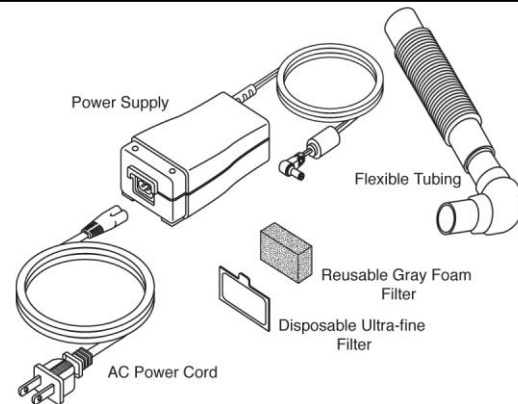
**Diagram 4**

Please contact your equipment provider for any questions, adjustments, or repairs.

Your local provider:



©Copyright The VGM Group
B.L.U.E. Sheet images, drawings, and text
courtesy of VGM contracted vendors.

All Medicare DMEPOS suppliers must be in compliance with CMS Supplier Standards in order to obtain and retain their billing privileges. These standards, in their entirety, are listed in 42 C.F.R. pt. 424, sec 424.57(c). A supplier must disclose these standards to all customers/patients who are Medicare beneficiaries (standard 16). Supplier Standard 12 includes "A supplier ...must instruct beneficiaries on use of Medicare covered items".